



UL, CE, CSA Certified

## Vacuum Science Simplified

We know vacuum applications can get complicated. FYRA was created to deliver scientific measurement and vacuum control simply with easy integration into almost any system in the market.



### *Piezo, Thermal, Active and Capacitance Manometers*



Bleed Valve    Bellows Valve



Plunger Valve    Dinamo\* Valve



## The Power of 4

FYRA gives you the essence of versatility with a touchscreen or dial interface and ability to measure and control across the full rough to medium vacuum range

\*Patent-pending proportional valve for precise vacuum control and venting in one with almost full KF25 bore to support high flow across the full range of medium and rough vacuum



## Example of a FYRA Application

Imagine a vacuum system that is controlled by a PLC, where the PLC sends an analog signal corresponding to a vacuum pressure level to be maintained. Meanwhile, the FYra sends back current vacuum pressure to the PLC.

In this application example, the other pieces of equipment would operate as follows (slots refer to image on right) :

### Dinamo Valve

The pressure can be maintained by the DigiVac Dinamo Valve. (Slot B)

### Capacitance Manometer

1000 Torr capacitance manometer would be the sensor to be used for the control of vacuum pressure. (Slot D)

### 531 Sensor

The 531 sensor is used at the inlet of the vacuum pump to monitor inlet pressure. (Slot C)

### Convectron

The convectron is put on the chamber in order to see the wide range base pressure of the system chamber. (Slot A)

### VacStable

The VacStable is used to sweep a specific amount of gas (sccm) through the chamber. (Slot F)

### WiFi Connection

View pressure in real time through vacuumnetwork.org, and log data through the USB interface.

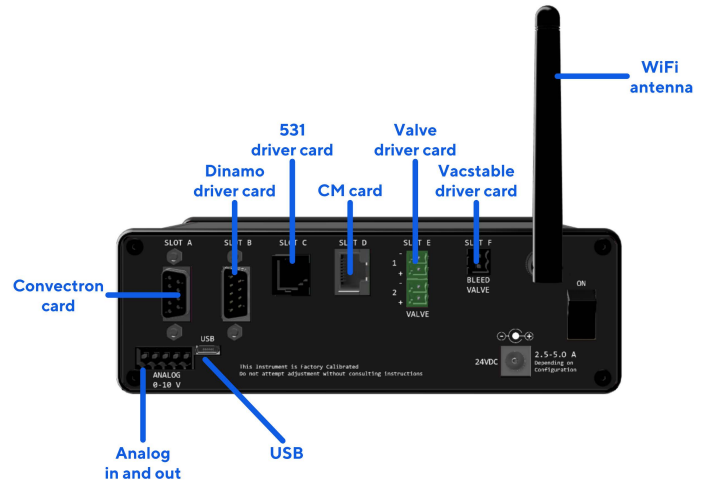
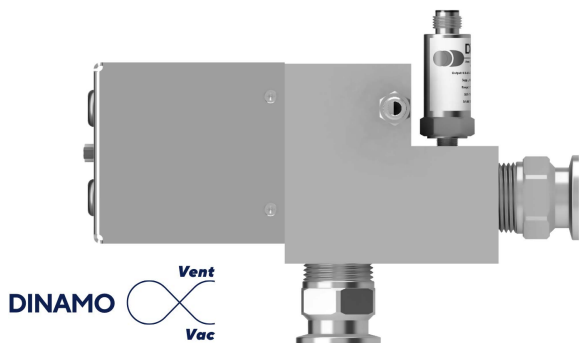

## SPECIFICATIONS

Power	100-240VAC 50/60Hz UL, CSA, CE Rated
Vacuum Interface	Dependent on sensor(s) chosen
Sensor	Dependent on sensor(s) installed
Range	Ability to support $10^{-10}$ Torr - 1000 Torr
Units	Torr, mbar, kPa, microns, millitorr, mmHg, Hectopascal
Mount	Pole mount; bench top
Display	3.9" touch screen display
Dimensions	6.5"x6.5"x2.5"
Controls	7 amp, 250 Volt (If applicable)
Telemetry Options	USB, Wifi, 0- 10 volts Analog out, 0- 10 volts Analog in
Valve Support	Dinamo, VacStable (Bleed), Solenoid-type Bellows and Plunger, 24V valves that are less than 24 Watts
Certifications	UL, CE, CSA

## SENSORS SUPPORTED BY FYRA

MKS Convectron	275071 (1/8" NPT), 275203 (KF16)
DigiVac	SEN-VGT500, SEN-775i, Quantum (SEN-DPP, SEN-DCP, SEN-DPCP)
Pfeiffer	PKR251, IKR251
Agilent	FRG700, PCG-750, PCG700, 531, 536, 531 equivalent, or PVG 500
Setra	730 capacitance manometers
Inficon	PSG500, PSG550, Porter, SKY, Stripe, MAG, MPG & MPG400